

Autonomous electric vehicle with 2 motor wheels

Pioneer 3-DX is a small lightweight two-wheel two-motor differential drive robot for indoor use. The robot are eight sonars, one battery, two wheel encoders, a microcontroller with ARCOS firmware, and the Pioneer SDK advanced mobile robotics software development package.

Pioneer research robots are the world's most popular intelligent mobile robots for education and research. Their versatility, reliability and durability have made them the preferred platform for advanced intelligent robotics.

Specifications

- Body: 1.6 mm aluminum (powder-coated)
- Tires: Foam-filled rubber
- Robot Weight: 9 kg
- Operating Payload: 17 kg
- Differential Drive Movement
- Turn Radius: 0 cm
- Swing Radius: 26.7 cm
- Max. Forward/Backward Speed: 1.2 m/s
- Rotation Speed: 300°/s
- Max. Traversable Step: 2.5 cm
- Max. Traversable Gap: 5 cm
- Max. Traversable Grade: 25%
- Traversable Terrain: Indoor, wheelchair accessible
- MIDI programmable piezo buzzer
- Main power indicator
- Battery charge indicator
- 2 AUX power switches
- System reset
- Motor enable pushbutton

Power

- Run Time: 8-10 hours w/3 batteries (with no accessories)
- Charge Time: 12 hours (standard) or 2.4 hrs (optional high-capacity charger)

Available Power Supplies:

- 5 V @ 1.5 A switched
- 12 V @ 2.5 A switched

Batteries

- Supports up to 3 at a time
- Voltage: 12 V
- Capacity: 7.2 Ah (each)
- Chemistry: lead acid
- Hot-swappable Batteries: Yes
- Direct plug-in

Dimensions (mm)

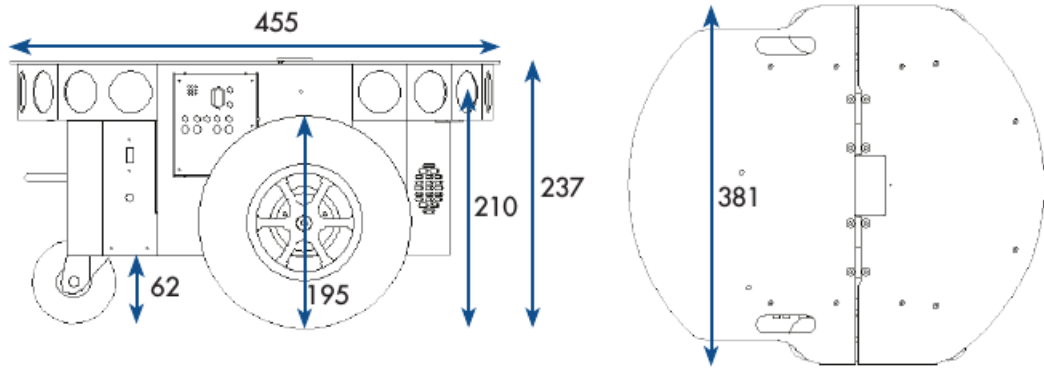

Core Software - included with all research platforms